

SIGN	DATE	DESCRIPTION	APPROVER
△			
THIS IS CAD DRAWING, DO NOT REVISE MANUALLY!!!			

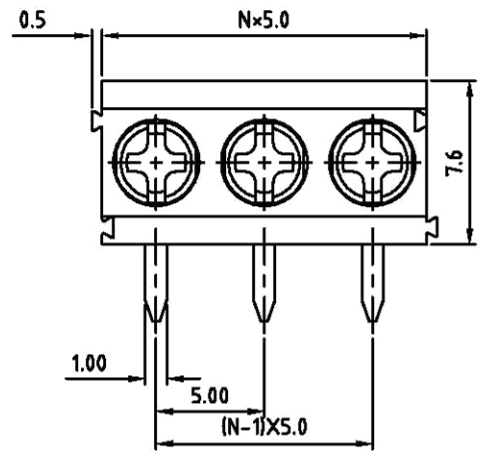

N=Number of contacts

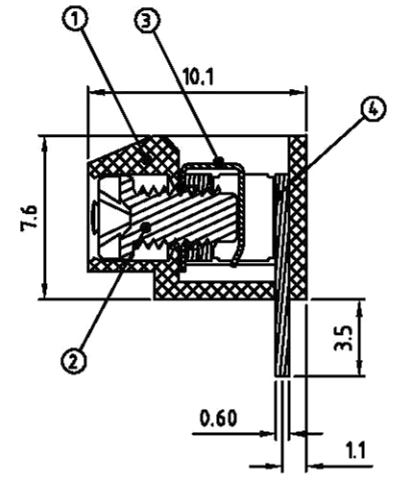

Materials

- | | |
|------------------------|--------------------------------------|
| Item 1 insulating body | Thermoplastic (UL94V-0) |
| Item 2 Steel screw | Screw, Zinc plating("+/-" slot type) |
| Item 3 Wire guard | Stainless steel |
| Item 4 Terminal body | Brass Tin plated |

Electrical

- Voltage rating: 300VAC
- Current rating: 8A
- Wire range:
- Solid wire(AWG): 14-26
- Stranded wire(AWG): 14-26
- Torque(Lb-In): 2.6
- Screw: M2.5
- Wire strip length: 5-6mm
- Withstanding Voltage: 1.6KV
- Operating temperature: -30°C to +105°C
- Soldering temperature: 250°C±10°C/5 Sec

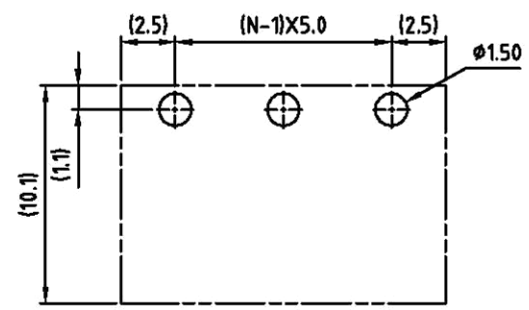

P.C.B. LAYOUT

X97703A/B				CUSTOMER COPY			
ALL RIGHTS RESERVED. REPRODUCTION OR ISSUE TO THIRD PARTIES IN ANY FORM WHATEVER IS NOT PERMITTED WITHOUT WRITTEN AUTHORITY FROM THE PROPRIETOR. PROPERTY OF ANYTEK TECHNOLOGY CO., LTD							
TITLE							
PART NO.				DWG NO.		BT30007	
APPROVED	CHECKED	DESIGNED	DRAWN	CUST NO.		Tolerance	
		熊海燕	熊海燕			UNIT: mm	X ±0.50
		11/08 06	11/08 06			SCALE: NONE	X.X ±0.30
				SHEET: 01/01	REV.: B	X.XX ±0.10	X° ±1°